

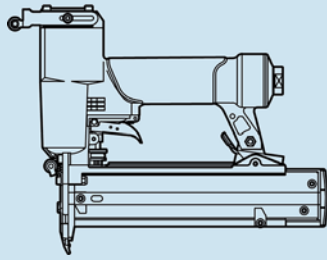

F21T GN-40A GLAZING STRIP

- Rubber comfort grip ensures a non-slip handling and reduces vibrations and fatigue
- No-mar tip and unique forked-type safety avoid marring of soft wood
- Reversible bumper for high durability and increased parts life
- Side window to see visible brads for reducing the incidence of dry-fire
- Patented Quick Clear permits the magazine to slide away from nose to clear jams
- Adjustable guides and rollers

TOOL TYPE



F21T GN-40A GS

TOOL CHARACTERISTICS

Height	Width	Length	Weight
222 mm	68 mm	285 mm	1.28 kg
8.74 inch	2.68 inch	11.22 inch	2.82 lbs

Pressure 5 - 7 bar | 70 / 100 psi

Air consumption per shot 0.43 l
Performances at 90 psi / 6.2 bar (0.62 MPa)

Lubricant Aerospace Lubricants Tribolube 12

FASTENER DATA

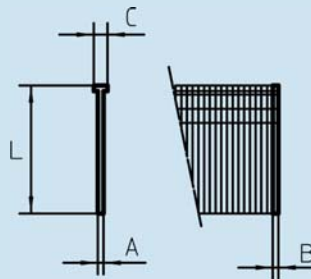

AxB) Shank	1.00 - 1.27 mm	0.039 - 0.050 inch
C) Head	2.20 mm	0.086 inch
L) Length	15 - 40 mm	5/8 - 1 9/16 inch
Magazine Capacity	105 brads	
Brad Type	GN Brads (18 gauge)	

NOISE VALUE

(EN 12549+A1 : 2008, EN ISO 4871 : 2009)

$L_{WA,1s}$: 98.70 dB (A) - $K_{WA,1s}$, 2.5

$L_{pA,1s}$: 91.00 dB (A) - $K_{pA,1s}$, 2.5

VIBRATION VALUE

(UNI ISO/TS 8662-11)

is below the declaration limit set by
UNI EN ISO 12100-1/2

ACTUATION & LOADING

Actuation System* 1
(Safety : SS)

Loading* Side Loading

*see instruction manual

APPLICATIONS

- glazing and beading
- glass bead moulding

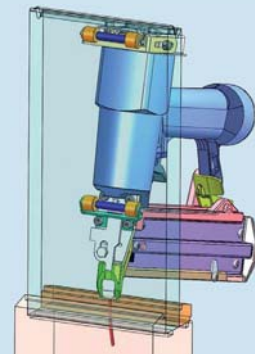
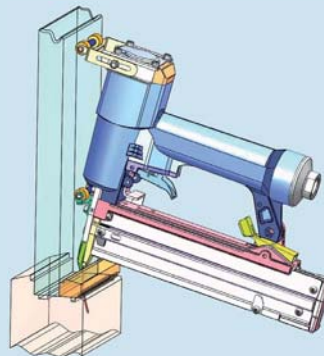

FASCO S.R.L. Italy

Via B. Buoizzi 2

I - 40057 Cadriano di Granarolo (BO)

Tel. +39 051 / 60 181 | Fax +39 051 / 766 325

fasco@fasco-tools.com | www.fasco-tools.com

FASCO[®]
AIR DRIVEN TOOLS

MEMBER OF THE
beck
FASTENER GROUP